

內徑圓槽刀 Internal radius turning tool

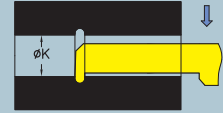
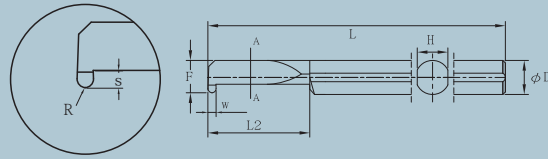
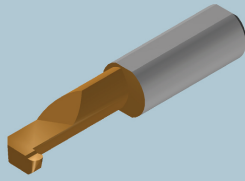

型號 EDP NO.	ØK	F	W/F 0.03	L2	L	r	S	ØD	在庫 stock	適用套筒 Applicable Sleeve
B53.4010-050R	4	3.6	1.0	10	40	0.5	0.8	4	●	SP.250-04** SP.5650-04**
B53.4010-075R	4	3.6	1.5	10	40	0.75	0.8	4	●	
B53.4010-100R	4	3.6	2.0	10	40	1.0	1.0	4	●	
B53.5015-050R	5	3.8	1.0	15	45	0.5	1.0	4	●	
B53.5015-075R	5	3.8	1.5	15	45	0.75	1.0	4	●	
B53.5015-100R	5	3.8	2.0	15	45	1.0	1.2	4	●	
B53.6015-050R	6	5.8	1.0	15	50	0.5	1.5	6	●	SP.250-06** SP.5650-06**
B53.6015-075R	6	5.8	1.5	15	50	0.75	1.5	6	●	
B53.6015-100R	6	5.8	2.0	15	50	1.0	1.5	6	●	
B53.8025-050R	8	7.8	1.0	25	62	0.5	2.0	8	●	SP.250-08** SP.5650-08**
B53.8025-075R	8	7.8	1.5	25	62	0.75	2.0	8	●	
B53.8025-100R	8	7.8	2.0	25	62	1.0	2.0	8	●	
B53.10030-050R	10	9.8	1.0	30	75	0.5	2.5	10	●	SP.250-10** SP.5650-10**
B53.10030-075R	10	9.8	1.5	30	75	0.75	2.5	10	●	
B53.10030-100R	10	9.8	2.0	30	75	1.0	2.5	10	●	
B53.10030-125R	10	9.8	2.5	30	75	1.25	2.5	10	●	
B53.10030-150R	10	9.8	3.0	30	75	2.0	2.5	10	●	
B53.12035-050R	12	11.8	1.0	35	80	0.5	2.5	12	●	
B53.12035-075R	12	11.8	1.5	35	80	0.75	3.0	12	●	
B53.12035-100R	12	11.8	2.0	35	80	1.0	3.0	12	●	
B53.12035-125R	12	11.8	2.5	35	80	1.25	3.0	12	●	
B53.12035-150R	12	11.8	3.0	35	80	2.0	3.0	12	●	

無"●"標示者為訂製品。Without "●" marking means custom products.
 有"●"標示者為在庫品。With "●" marking means items in stock.

內徑圓槽刀 Internal radius turning tool

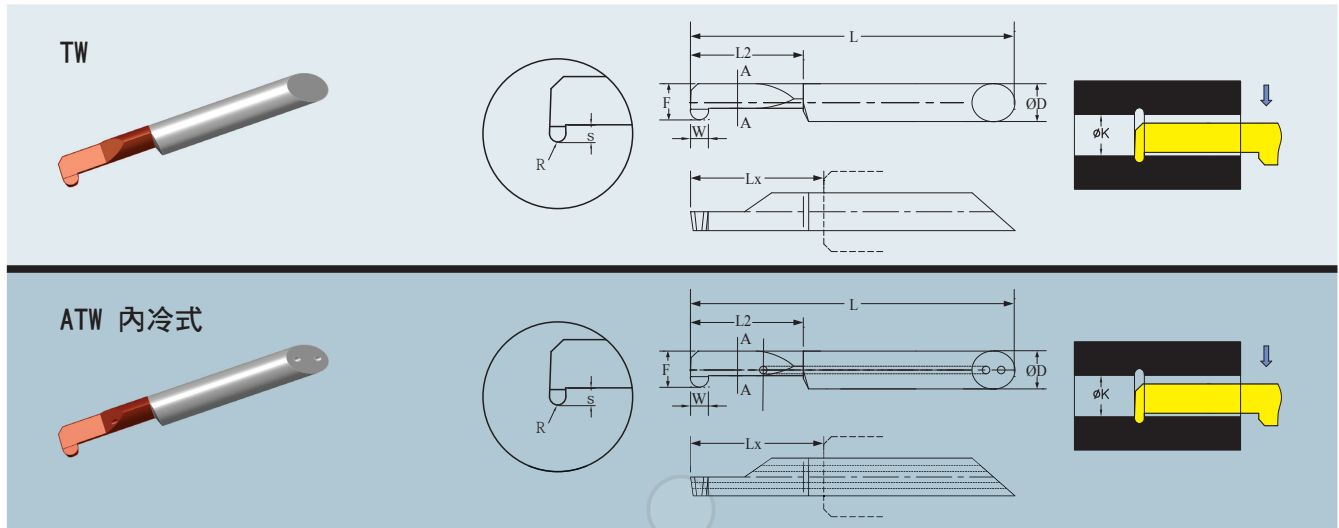

型號 EDP NO.	內冷式 型號 EDP NO.	ØK	F	W±0.03	L2	Lx	r	S	ØD	在庫 stock	適用套筒 Applicable Sleeve
TW B53.4010-050R	ATW B53.4010-050R	4	3.8	1.0	10	12	0.5	0.8	4		SP.380-04**
TW B53.4010-075R	ATW B53.4010-075R	4	3.8	1.5	10	12	0.75	0.8	4		
TW B53.4010-100R	ATW B53.4010-100R	4	3.8	2.0	10	12	1.0	1.0	4		
TW B53.5015-050R	ATW B53.5015-050R	5	4.8	1.0	15	17	0.5	1.0	5		SP.380-05**
TW B53.5015-075R	ATW B53.5015-075R	5	4.8	1.5	15	17	0.75	1.0	5		
TW B53.5015-100R	ATW B53.5015-100R	5	4.8	2.0	15	17	1.0	1.2	5		
TW B53.6020-050R	ATW B53.6020-050R	6	5.8	1.0	20	23	0.5	1.5	6		SP.380-06**
TW B53.6020-075R	ATW B53.6020-075R	6	5.8	1.5	20	23	0.75	1.5	6		
TW B53.6020-100R	ATW B53.6020-100R	6	5.8	2.0	20	23	1.0	1.5	6		
TW B53.7025-050R	ATW B53.7025-050R	7	6.8	1.0	25	28	0.5	1.8	7		SP.380-07**
TW B53.7025-075R	ATW B53.7025-075R	7	6.8	1.5	25	28	0.75	1.8	7		
TW B53.7025-100R	ATW B53.7025-100R	7	6.8	2.0	25	28	1.0	1.8	7		
TW B53.8030-050R	ATW B53.8030-050R	8	7.8	1.0	30	33	0.5	2.0	8		SP.380-08**
TW B53.8030-075R	ATW B53.8030-075R	8	7.8	1.5	30	33	0.75	2.0	8		
TW B53.8030-100R	ATW B53.8030-100R	8	7.8	2.0	30	33	1.0	2.0	8		

無"●"標示者為訂製品。Without "●" marking means custom products.
 有"●"標示者為在庫品。With "●" marking means items in stock.